



# VTB\*\*SC\*\*-O Series 50 Watt DC/DC Power Supply



Available Inputs:

- 12VDC Nom (DC9~18V)
- 24VDC Nom (DC 19~36V)
- 48 VDC NOM (DC 38 ~ 63 V)
- 110 VDC NOM (DC 85~160V)

PART No. Description: VTB<sup>↑</sup>SC<sup>↑</sup>-O

2 Year Warranty      Output Voltage      Input Voltage (nominal)



		UNIT	VTB**SC12-O	VTB**SC24-O	VTB**SC48-O	VTB**SC110-O
<b>INPUT</b>	<b>Nom Voltage (Range)</b>	V	DC 12V (9~18)	DC 24V (19~36)	DC 48 (38~63)	DC 110V (85~160)
	<b>Current Typ.</b>	A	8.0	3.8	2.0	0.85
	<b>Inrush Current</b>	A	40 ( Ta=25°C , Io=100% at cold Start )			
	<b>Leakage</b>	mA	3.5			
			VTB05SC**-O	VTB12SC**-O	VTB15SC**-O	VTB24SC**-O
<b>OUTPUT</b>	<b>Nominal Voltage</b>	VDC	5	12	15	24
	<b>Voltage Range</b>	VDC	4.95 ~ 5.05	11.88~12.12	14.85~15.15	23.76~24.24
	<b>Current</b>	A	10	4.2	3.4	2.5
	<b>Total Pwr</b>	W	50	50.4	51	60
	<b>Efficiency</b>	%	70	75	78	80
	<b>Line Regulation</b>	mV	25	60	75	120
	<b>Load Regulation</b>	mV	50	120	150	240
	<b>Ripple</b>	mVp-p	50	120	150	240
	<b>Ripple Noise Maximum</b>	mVp-p	100	170	200	290
	<b>Temp Drift</b>	mV	75	180	225	360
	<b>Rise Time</b>	mS	500 max [DC IN 9V, Io =100%]			
	<b>Hold up Time</b>	mS	10 typ [DC IN 9V, Io =100%]			
	<b>OVP</b>	V	5.75~7.0	13.8-16.8	17.25~21.0	26.4~33.6
	<b>OCP</b>	A	11.0~13.0	4.6~5.5	3.7~4.4	2.8~3.3
<b>Cooling</b>		Convection				
<b>ISOLATION</b>	<b>Input - Output</b>	AC 1.5KV 1 min, cut-off: 20 mA / DC 500V 100MΩ				
	<b>Input - F.G</b>	AC 1.5KV 1 min, cut-off: 20 mA / DC 500V 100MΩ				
	<b>Output -F.G</b>	AC 500V 1 minute cut-off: 100mA, DC 500V 100MΩ				
<b>Environment</b>	<b>Operating temp</b>	-10 ~ +50°C, 20 ~ 90% RH(Non condensing)				
	<b>Storage</b>	-10 ~ +70°C, 20 ~ 90% RH(Non condensing)				
	<b>Vibration</b>	10 ~ 55Hz at 1G, 3 minutes period, 30 minutes along X, Y and Z axis				
<b>Dimension</b>	<b>WxHxL</b>	mm/g	97x37x178 / 400			





## BLOCK DIAGRAM

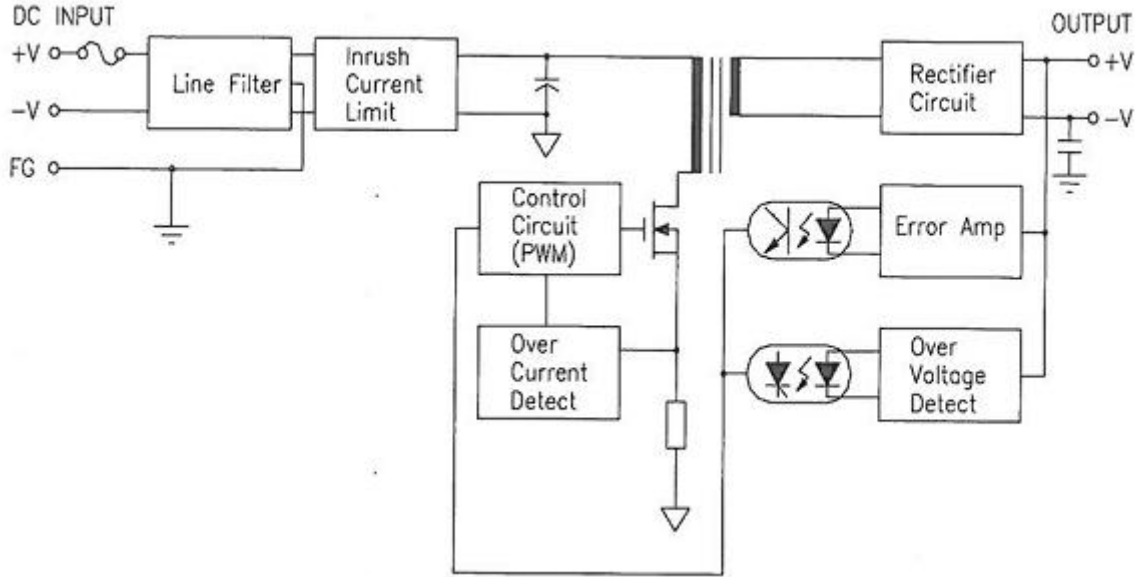

## Terminal Output

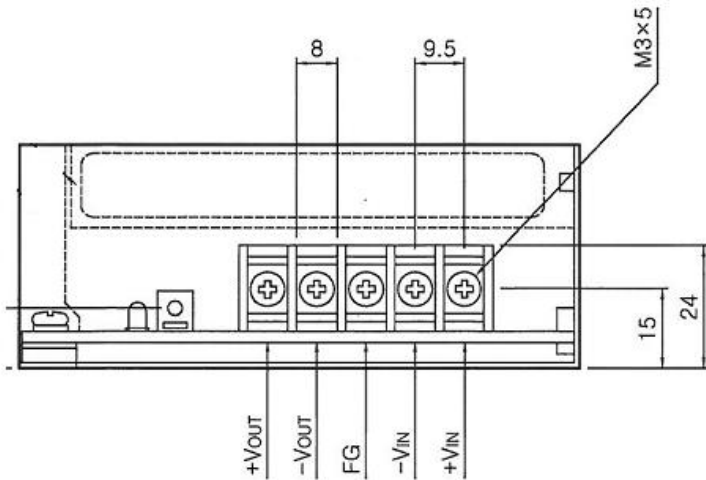

Mark	Pin Connection	Function
+Vin	DC Input (+)	DC Input Terminal (+) Fuse In Line
-VIN	DC Output (-)	DC Input Terminal (-)
F.G	Frame Ground	DC Ground Terminal/ Chassis Ground
+V	DC Output (+)	DC Output Terminal (+)
-V	DC Output (-)	DC Output Terminal (-)





## DIMENSIONAL DRAWING (mm)

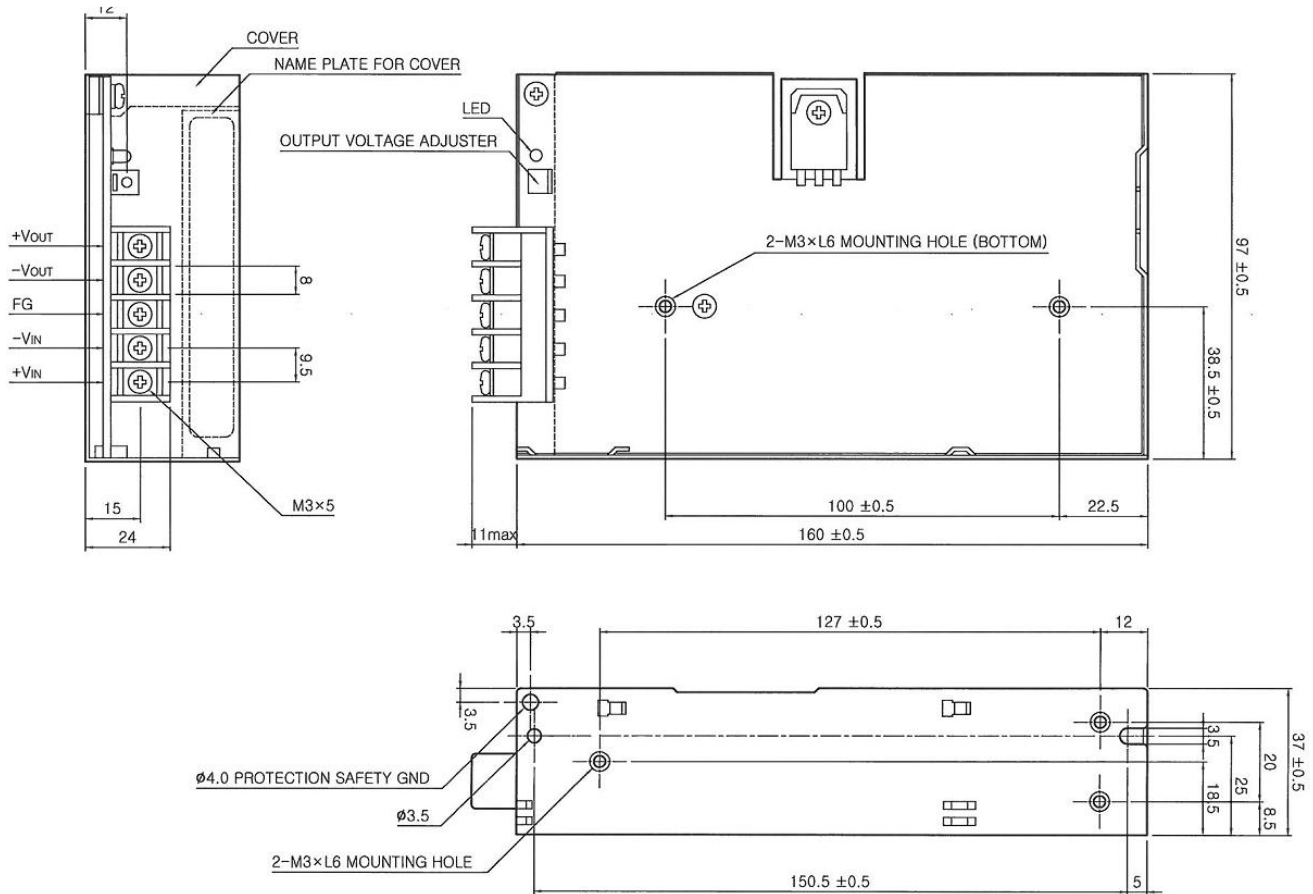



## OUTPUT DERATING CURVE AND RECCOMENDED MOUNTING DIAGRAM

